

Purification of some Calcium and Magnesium Waste by Hydrodynamics Classification

L.M. Taubert, M. Milos and L. Sayti

Department of Inorganic Chemistry, Institute of Chemistry - Timisoara of the Romanian Academy, Bd. Mihai Viteazu Nr.24, 300223 Timisoara, Romania, Phone: (040) 0256-491818, Fax: (040) 0256-491824, E-Mail: lidiat@acad-icht.tm.edu.ro

Abstract: In the manufacturing process of magnesium carbonate and oxide from dolomites by carbon dioxide leaching are evacuated calcium carbonate waste, on one hand and on the other hand, in the carbide industry could be obtained calcium carbonate by practical application of some subsized lime fractions-containing waste. In order to obtain calcium carbonate in different sorts as final products from the mentioned waste, studies regarding the elimination of impurities were realised. For this purpose, the hydrodynamics classification in centrifugal field by passing the slurries through batteries of hydrocyclones, was taking into consideration as separation method. Rubber hydrocyclones of different diameters were fed through aqueous slurries of calcium and magnesium hydroxides, and through slime of calcium carbonate respectively. Different working variants, defined by pressure, flows, slurries concentration, nozzles opening ratios, were applied. The obtained results relieve that the efficient using of hydrocyclones is possible, in order to homogenize and to purify the lime and the calcium carbonate slurries, remarking good extraction yields.

Keywords: dolomite, lime, calcium carbonate, hydrodynamics classification, hydrocyclone

1. Introduction

A synthesis of the purification experiments for some waste containing lime and calcium carbonate is presented in the work. The experiments were carried out in order to establish some processing technologies of these waste to calcium carbonate as final products in different sorts, for various applications.

In the carbide industry, after the lime crushing, a subsized fraction is separated, having a considerable content of impurities. Since it is a powdery fraction, the subsized lime (< 5 mm) cannot be used in the carbide furnace and, therefore, is considered a waste [1].

During the manufacturing process of magnesium carbonate and oxide from dolomites by carbon dioxide leaching, calcium carbonate precipitates, including the impurities from the initial raw material. Due to the instability of the $Mg(HCO_3)_2$ solutions, under the conditions from industrial installations, besides the impure calcium carbonate, magnesium carbonate precipitates too; the ratio between the two carbonates is of 3 - 4 : 1. The waste result in considerable amounts, corresponding to a half of the initial dolomite [2].

To separate the impurities (aluminium and iron oxides, different silicates, unburnt stone) from the two waste, in order to use them at the manufacture of calcium carbonate, the hydrodynamics classification in centrifugal field can be taken into account, by using apparatus of hydrocyclone type [3,4].

The use of hydrocyclones is based on the effect of centrifugal force upon the solid particles in liquid medium where they are in suspension. The centrifugal forces which act upon the particles that pass through the hydrocyclone are by some hundred times higher than the gravitational forces, allowing thus the processing of fine grain

suspensions, for which the gravitational methods are inefficient. As far as the size of the particles passed through the hydrocyclone decreases, the influence of the gravitational forces decreases proportionally to the decrease of the particles mass. Thus is chosen the field in which the hydrocyclone is used, evincing also its importance for the preparation of the fine grained raw materials [5].

Purification experiments of the waste from the two mentioned industries, namely of the calcium carbonate slime from the industry of magnesium products, as well as of the lime milk obtained from subsized lime, are presented in the work. The aim was the impurities removal and the products enrichment in useful substances by means of hydrodynamics classification. The applied method for separation have consisted in passing the slurries through batteries of different diameters hydrocyclones. Various working variants defined by the variation of pressure, flows, slurries concentration, nozzles opening ratios, were used.

2. Experimental

2.1. Materials

Limestones used as raw materials in the carbide industry are of variable quality, usually second-rate and inferior. The chemical analysis evinced the low content of useful substance, CaO (53.98 - 54.31%) and high content of impurities, especially SiO_2 (0.21 - 1.22%) and of those insoluble in hydrochloric acid (0.32 - 1.39%). The waste-lime (< 5mm), resulted by sorting of these limestones, have also contained significant amounts of impurities, which are concentrated in the fine fractions, accompanying and impurifying the useful product CaO. Since the lime milk

slurry, obtained from the waste-lime, has a low content of useful substance and is highly impurified, cannot be used as raw material for the fabrication of a good quality calcium carbonate.

In the industry of magnesium products, native dolomites are used as raw materials for the manufacturing of the magnesium carbonate and oxide. They can be found in lots of mineral deposits in our country, but for the fabrication of mentioned products, significant amounts from the deposit of Voslobeni were used. The chemical analysis carried out during two years evinced a variation, in wide limits, both of the useful substances (30.06 - 33.93 % CaO and 19.31 - 22.93 % MgO) and especially, of the impurities content, namely 0.27 - 2.46 % SiO₂ and 0.15 - 2.58 % R₂O₃ (Al₂O₃ + Fe₂O₃). During the technological process, in the carbonation columns result Mg(HCO₃)₂ solutions, in which particles of solid calcium carbonate are suspended. Due to the instability of these solutions, during their separation from the calcium carbonate precipitate, magnesium carbonate precipitates too; the two carbonates will be lost together in the mud of the thickener, besides the impurities from the initial dolomites. Like in the initial dolomites, the same inconstancy of the average composition of the product considered as waste, was noticed: CaCO₃ content was of 70.6 - 75.5%, MgO from magnesium carbonate was of 8.8 - 14.1%, insoluble impurities in hydrochloric acid (insoluble) were of 0.6 - 1.4%, as well as 0.8 - 1.1% iron and aluminium oxides [6].

2.2. Working method

The two before mentioned products, considered as waste, were purified by hydrodynamics methods in centrifugal field, in order to separate the undesirable impurities, using classification apparatus of hydrocyclone type. Such apparatus were installed in two factories of country, where the equipments were arranged in view of the experimental implementation on the flow sheet.

It had mention that many authors took interest in the theoretical description of hydrocyclones, e.g. Trawinski (2003) [7,8].

In Fig. 1 is presented a type of hydrocyclone. As it can be seen, its superior part is a short cylinder (1), and its inferior part has the shape of a cone with its top directed down (2). The rotational motion in hydrocyclone is obtained by the tangential feeding of slurry through the feeding orifice from the cylindrical part of hydrocyclone, by means of a pump; the pressures of $(0.5 - 3.5) \cdot 10^5$ Pa and speeds of 3 - 9 m/s were used. After entering the hydrocyclone, the slurry comes up against the wall of the cylindrical part and flows as a thin layer, obtaining thus a descending helicoidal current along the wall of the cone (2). Since under normal conditions of flow and pressure at feeding, through the underflow orifice (4) cannot be evacuated the whole amount of fluid, a part of it (a bigger part usually) is forced to change direction near the orifice, moving vertically to the superior part of the hydrocyclone, from where is discharged through the overflow houl (5). As this part of the current has also a rotational motion, the resultant is an interior spiral in another peripheral spiral,

both having the same rotational sense in transversal section, with reverse current motion in longitudinal section.

From technological point of view, upon the solid particles suspended in the liquid that passes through the hydrocyclone act, on one hand, a centrifugal force brought about by the centrifugal acceleration, and on the other hand, a centripetal force resulted from the centripetal radial circulation. The resultant force which decides whether a particle will be drawn in the overflow or in underflow, depends, first of all, on its size and specific weight, as well as on the specific weight of the medium; it is also influenced by the extent of centrifugal force, as well as of the centripetal one, which act upon the solid particle. These forces are conditioned by the building parameters of the hydrocyclone, by the feeding pressure, by the medium viscosity and by the concentration of feed slurry.

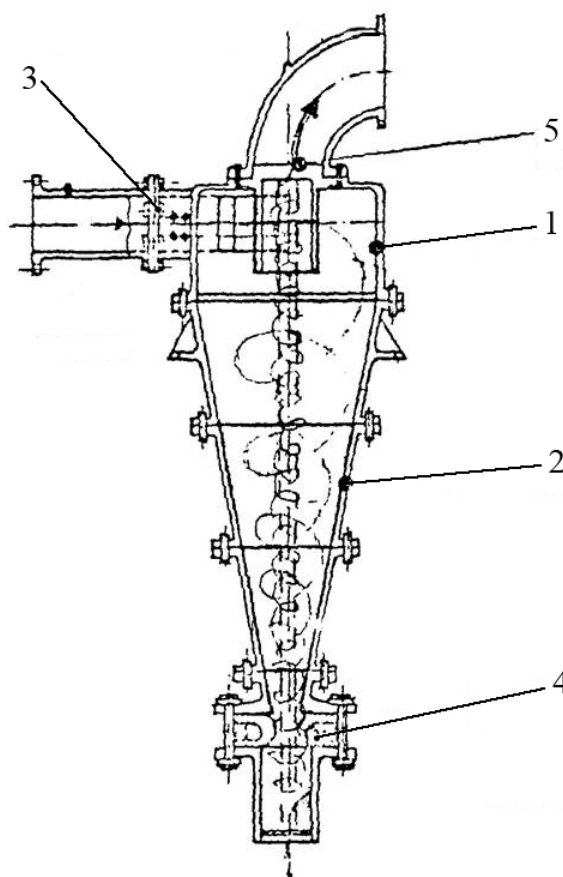

Figure 1. Hydrocyclone configuration: 1 - cylindrical section of the hydrocyclone body; 2 - conical section; 3 - feed nozzle; 4 - underflow nozzle; 5 - overflow nozzle

Rubber hydrocyclones of different diameters, namely 100 mm and 45 mm, were used during the experiments. They were fed with aqueous slurries of calcium and magnesium hydroxides and with slime of calcium carbonate, respectively. The experiments were carried out using different working variants, depending on the feed flow, working pressure, different values of the ratio between the orifices of overflow nozzle (doo) and that of underflow nozzle (duo).

The purification of slurries was realised in 2 steps, namely:

- in the first step, a hydrocyclone of $D = 100$ mm was used in order to discharge the bulky particles from the slurry;

- in the second step, a hydrocyclone of $D = 45$ mm was used in order to restrain the granulometric spectrum and for a more advanced reduction of the impurifying substances content.

The classification technology of slurries in 2 two steps was performed in closed-circuit arrangement, using batteries of hydrocyclones with different diameters. As it can be noticed, the slurry from a storage vessel feeds the hydrocyclone with $D = 100$ mm; its overflow is collected in another storage vessel and the part containing heavy components into the drain is evacuated. The slurry collected in the second vessel feeds the hydrocyclone of 45 mm diameter, in closed-circuit too.

In each working variant, flow measurements and sample reappings from the feeding slurries, from overflow and underflow were performed, in order to establish the main technological indicators, as well as the qualitative efficiency of operation.

The characterization of the collected samples was realised by means of chemical analyses in laboratory.

The experiments were performed in pilot phase.

3. Results and Discussion

The working variants used for the purification both of the lime milk and of the calcium carbonate slime are evinced by obtained results and distinctly presented further on.

3.1. Purification of lime milk from the carbide industry

Lime milk is obtained by slaking the waste-lime from the carbide industry. The lime milk was diluted until a slurry was obtained with an average concentration of 16% solid. The hydrocyclone with $D = 100$ mm was fed with this slurry in the first step of purification; the average composition is the following: 65.72% CaO, 1.79% SiO₂, 0.31% Al₂O₃ and 4% Fe₂O₃.

Some working variants, in 2 classification steps, as well as the significant results concerning the extraction yields, both of the useful product and of the impurifying substances, are presented in Table 1.

The data presented in Table 1 evince the efficiency of the separation process, indicated by an increase in the content of useful substance (CaO) and a decrease in the content of impurifying substances (SiO₂, Al₂O₃, Fe₂O₃, insoluble in HCl) in the product from the hydrocyclone overflow. At the same time, the decrease in the CaO content and the increase in impurifying substances in underflow is noticed.

In the first step of separation, by means of the hydrocyclone with bigger diameter ($D = 100$ mm), a desanding of the lime slurry was performed; thus the content of SiO₂ increased visibly in the underflow from

hydrocyclone, in all the presented variants. For instance, in case of B variant, the content of SiO₂ increases from 0.57 % in the feeding product to 2.92 % in the underflow, and is reduced to 0.34 % in the overflow (purified product).

In the second step of separation, using the hydrocyclone with smaller diameter ($D = 45$ mm), the content of impurifying substances in the overflow product have decreased.

Depending on the applied variant, the efficiency of separation process is obvious by the characteristics of the product obtained in the hydrocyclone overflow, its quality being significantly improved as compared to that of the product fed in the hydrocyclone.

3.2. Purification of calcium carbonate slime from the magnesium products industry

The calcium carbonate slime, resulted from the thickener, was diluted to slurries with concentration corresponding to the feeding of hydrocyclones, i.e. about 132 g/dm³. The feeding flow of calcium carbonate-waste slime was of 9 m³/h. The overflow from the hydrocyclone with $D = 100$ mm was fed into the hydrocyclone with smaller diameter ($D = 45$ mm), with flow of 1.7 - 2.2 m³/h. The useful product is the fine fraction obtained in the overflow of the last hydrocyclone; the purified product in 2 steps was then processed to calcium carbonate as final product.

Some experimental variants, which were applied on the installations of testing, as well as the obtained effect, evinced by the variation of the samples composition, taken periodically, are presented in Table 2.

For a correct interpretation of the obtained results, the difficulties that occurred in the practical performance of the experiment, realised on a rather large scale, must be evinced. Thus, it should be mentioned that the deposition of the bulky fraction from slime, silica especially, was preliminary realised in the vessel by which it was conveyed to the testing installation. Therefore, from the slurry that fed the hydrocyclone in the first step (B, C, D variants in Table 2), the sand was removed before entering the classification apparatus. However, when the opening ratio of the overflow and underflow nozzles (doo/duo) was established, the real grain size of the particles in the slurry was considered. The content of fine fractions in the hydrocyclone products is determined by the value of doo/duo ratio. From the researches have resulted that the maximum efficiency is obtained in variant B (doo/duo = 2.6) and variant C (doo/duo = 3.0) respectively. The reduction of the underflow nozzle (variant D) causes the discharge of a part from the bulky product through the overflow nozzle.

The analysis of results have evinced the concentrating of useful product - calcium carbonate - in the overflow of the hydrocyclone with $D = 100$ mm; its extraction exceeds 81% in 3 variants from the Table 2 (B, C, D). The decreases of the impurifying substances were not significant under the mentioned conditions; a decrease up to 27 % of the substances insoluble in HCl (variant D) and up to 4 % of the iron oxides (C and D variants) has been noticed.

TABLE 1. Hydrodynamics classification of the lime milk in 2 steps

Variant	Working parameters					Lime slurry in	Chemical analysis (%)					
	D (mm)	dfo (mm)	doo (mm)	duo (mm)	P (10 ⁵ Pa)		SiO ₂	CaO	MgO	Al ₂ O ₃	Fe ₂ O ₃	Insoluble
A	100	20	20	10	1.1	Feed	0.52	68.88	0.47	0.68	0.19	0.31
						Overflow	0.31	69.86	0.47	0.69	0.13	0.10
						Underflow	1.76	66.12	0.47	0.70	0.58	1.57
B	100	20	20	8	1.1	Feed	0.57	69.10	0.47	0.82	0.17	0.46
						Overflow	0.34	70.13	0.47	0.46	0.14	0.26
						Underflow	2.92	65.48	0.49	2.24	0.51	2.46
D	100	20	18	8	1.1	Feed	0.67	69.28	0.48	0.66	0.19	0.38
						Overflow	0.38	69.78	0.48	0.56	0.14	0.20
						Underflow	2.28	66.46	0.46	1.23	0.47	1.42
B ₁	45	9	10	8	2.2	Feed	0.56	69.72	0.48	0.76	0.14	0.28
						Overflow	0.40	70.63	0.47	0.62	0.13	0.22
						Underflow	0.81	68.26	0.50	0.88	0.15	0.37
B ₂	45	9	10	6	2.2	Feed	0.62	70.06	0.49	0.72	0.13	0.30
						Overflow	0.46	70.72	0.49	0.64	0.12	0.26
						Underflow	1.08	67.75	0.49	1.00	0.16	0.42
B ₅	45	9	8	6	2.2	Feed	0.50	69.11	0.47	0.52	0.14	0.34
						Overflow	0.38	70.98	0.49	0.40	0.14	0.20
						Underflow	0.69	66.06	0.44	0.72	0.14	0.56

TABLE 2. Hydrodynamics classification of the calcium carbonate slime in 2 steps

Variant	Working parameters					CaCO ₃ slime in	Chemical analysis (%)				
	D (mm)	dfo (mm)	doo (mm)	duo (mm)	P (10 ⁵ Pa)		Insoluble	R ₂ O ₃	Fe ₂ O ₃	MgO	CaCO ₃
B	100	7 x 45	18	7	1 - 1.1	Feed	1.06	1.10	0.24	9.98	78.21
						Overflow	0.86	0.98	0.24	9.15	81.82
						Underflow	1.35	1.26	0.24	11.29	75.22
C	100	7 x 45	18	6	1 - 1.1	Feed	1.04	1.11	0.24	9.87	78.25
						Overflow	0.81	1.00	0.23	8.87	81.46
						Underflow	1.68	1.11	0.27	12.58	73.52
D	100	7 x 45	18	5	1 - 1.1	Feed	1.06	1.11	0.24	9.87	78.25
						Overflow	0.77	1.10	0.23	9.00	81.71
						Underflow	2.17	1.14	0.28	13.20	79.71
E	45	5 x 12	10	5	2.0	Feed	0.87	0.77	0.23	8.77	82.46
						Overflow	0.80	0.70	0.22	7.50	83.50
						Underflow	1.25	0.98	0.27	10.38	76.82
K	45	5 x 12	8	4	2.0	Feed	0.87	0.75	0.23	8.77	82.46
						Overflow	0.76	0.59	0.23	6.62	83.73
						Underflow	1.08	0.65	0.31	13.20	78.20

In the second step of classification, by means of the hydrocyclone with smaller diameter ($D = 45$ mm), the improvement of the technical parameters of calcium carbonate was meant and achieved, by decreasing the classification size. From qualitative point of view, only a slight increase in the CaCO₃ content was noticed, concomitantly with a small reduction of the substances insoluble in HCl (13%) and of R₂O₃ (21%) in K variant. In the above presented experiment, the classification effect in this step is rather low due to the high content of fine fractions in the product that feeds the hydrocyclone, as well as due to the presence of some impurifying substances of advanced fineness. The concentrating of the R₂O₃ type oxides, which in fact are clay and iron compounds, in the fine fraction from the hydrocyclone overflow, evinces that they have a granulometry quite similar to that of the useful components and are finely disseminated in the calcium carbonate slime. Therefore, such substances will accompany the fine fraction from the hydrocyclone overflow.

4. Conclusions

Considering the results obtained in the performed experiments, it can be estimated that the purification of the lime milk from lime-waste and of the calcium carbonate-waste, by hydrodynamics classification in 2 steps, is efficient to achieve the proposed aim.

After the classification process in 2 steps, both of the lime milk and of the calcium carbonate slime, products with a higher content of useful substances (CaO, CaCO₃) and lower content of impurifying substances (SiO₂, Al₂O₃, Fe₂O₃, insoluble in HCl) are obtained, as compared to the characteristics of the initial slurry.

In case of the classification in centrifugal field, using hydrocyclone apparatus, the extraction yield and the quality of the purified products depend mainly on the ratio between the orifice of the overflow nozzle and that of the underflow one.

The proposed purification technologies can contribute to the superior practical application of the two waste, i.e.

sub-sized lime from the carbide industry and calcium carbonate slime from the industry of magnesium products, by obtaining of high quality calcium carbonate as final product.

When dolomites are used as raw materials for fabrication of the magnesium oxide, the operations carried out tend to the elaboration of a procedure for obtaining calcium carbonate coupled on the industry of magnesium products. Thus, both components from the raw materials, i.e. magnesium and calcium, can be entirely turned to account.

REFERENCES

1. Milos M., Careja V., and Sayti L., *Proceedings "New trends and strategies in the chemistry of advanced materials with relevance in biological systems, technique and environmental protection"*, Timisoara, Romania, **2007**, 141 - 144.

2. Policec S. L., Taubert L. M., Bucerzan I., Morovan I., Fenyves L., and Kudler A. M., *Procedeu de obținere a carbonatului de calciu și/sau carbonatului de magneziu*, RO Patent 114441, **1999**
3. Taubert L., and Princz E., *Filtrieren und Separieren F&S*, 19(1), **2005**, 11 - 12.
4. Taubert L., Milos M., and Sayti L., *Book of Abstracts of the 2nd Symposium "New trends and strategies in the chemistry of advanced materials with relevance in biological systems, technique and environmental protection"*, Timisoara, Romania, **2008**, 58.
5. Dinter O., *Hidrocicloane și folosirea lor*, Editura Tehnica, Bucuresti, **1965**.
6. Taubert L., *Proceedings of the 9th Symposium on Analytical and Environmental Problems*, SZAB, Szeged, Hungary, **2002**, 41-45.
7. Trawinsky H., *Filtr. Sep.*, 6 (7/8), **1969**, 361 - 367.
8. Trawinsky H., in M. Bohnet, C. J. Brinker, B. Cornils, et al., *Ullmann's encyclopedia of industrial chemistry*, 17, Eds. Weinheim: Wiley-VCH, **2003**, 77 - 84.

Received: 06 October 2009

Accepted: 05 November 2009